

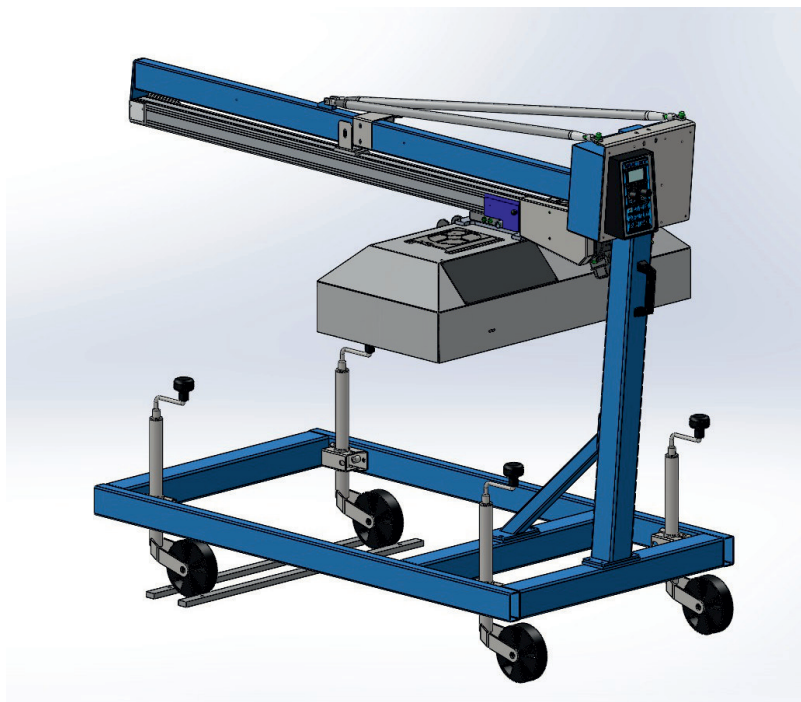



PERFECTION IN SCREENPRINTING

# Verdrahtungsplan wiring diagram Moving Flash 400V



Inhalt:	Seite / page	Contents:
Deckblatt	..... 1	cover sheet
Blockschaltbild	..... 2	block diagram
Steuerungseinheit	..... 3	control unit
Klemmenblock	..... 4	terminal block

	Wiring diagram Moving Flash 400V
	Deckblatt/ cover sheet
REV 2.6	Seite/page 1

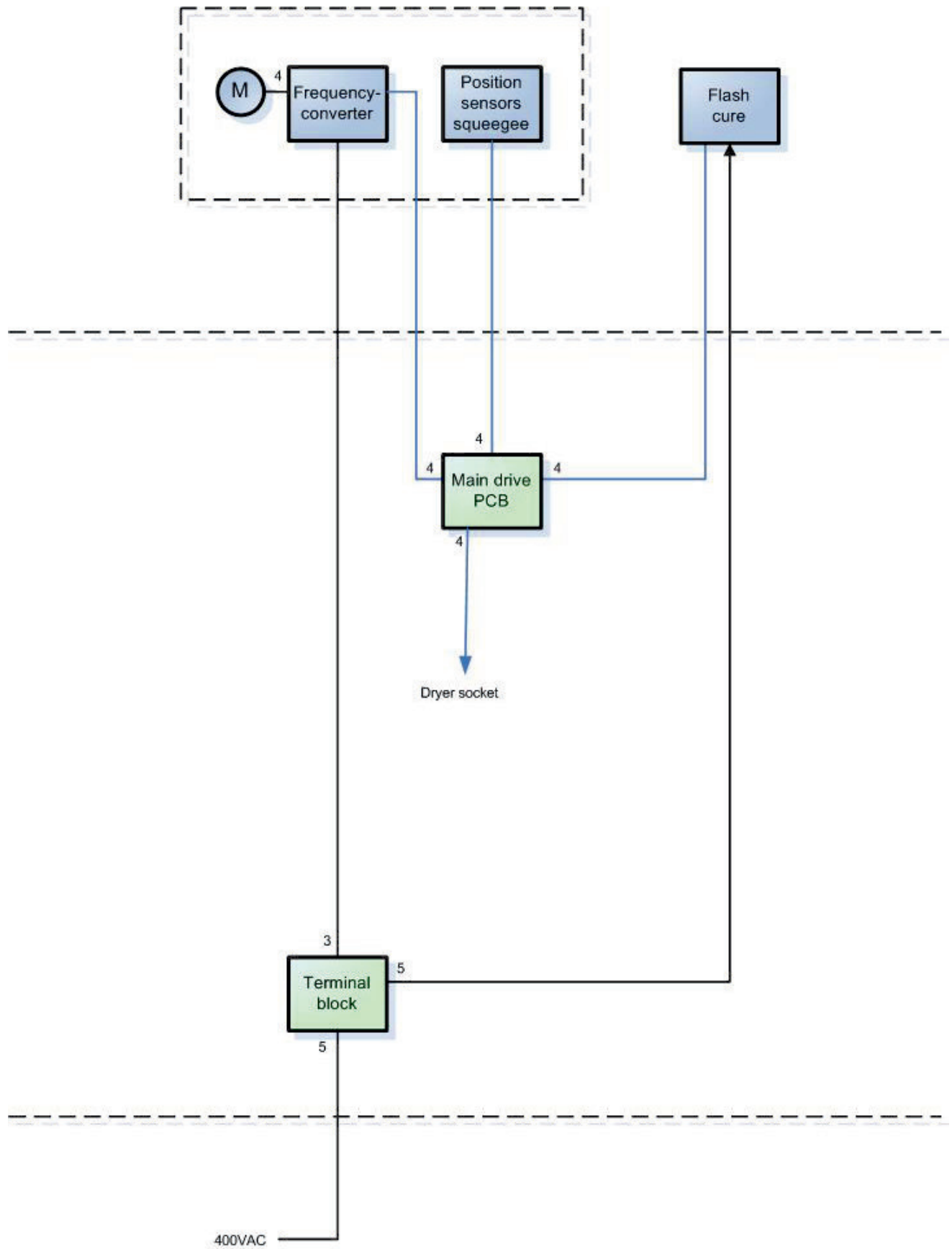

Tockner Signalanschluss/  
dryer signal connector

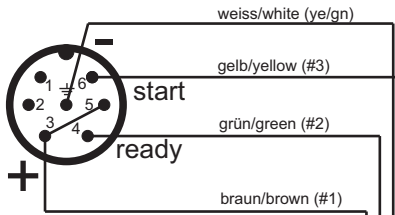

X1  
Klemmblock/  
terminal block

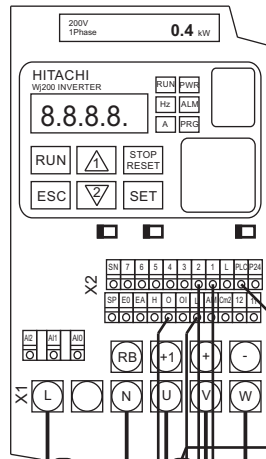

**U1**  
Frequenzrichter/  
frequency converter  
07-0-0-0133-6

M1  
Motor Rakelarm  
squeegee arm motor  
07-0-0-0639-0

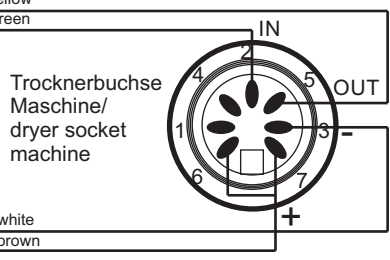
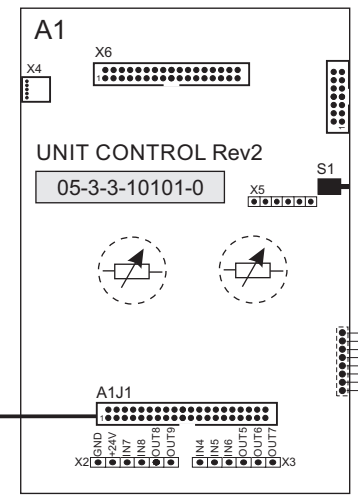
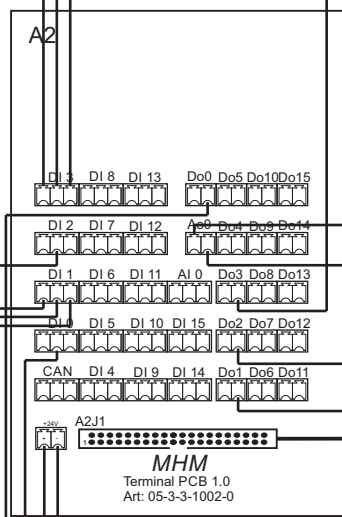

Kabel Rakel/  
cable squeegee  
07-0-0-0005-1

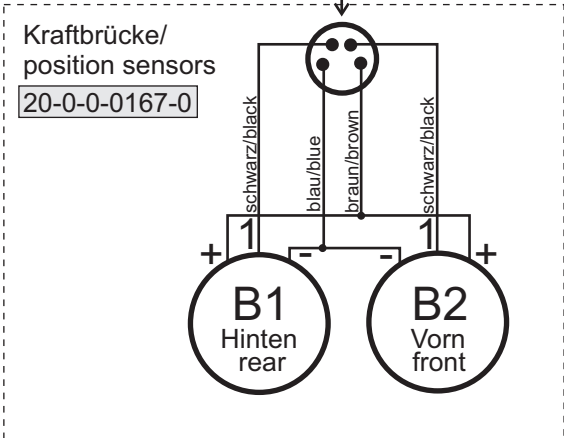
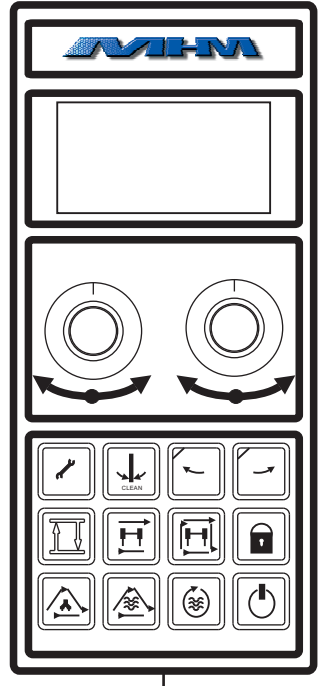

Zwischentrockner/  
flash cure  
QC 8044 MW

